



5. Connect and power-up:

- a. Connect the AXUM-Rack and the AXUM-UI's to 1 network.
Be sure only one AXUM is active in your network! Power down all other AXUM-Rack and/or AXUM-UI's
- b. Power-up the AXUM-Rack and AXUM-UI's you work on.
- c. The ACT-LED's on the Rack stop blinking fast and start blinking slowly.

6. Setup the AXUM system.

- a. Go to the AXUM site: <http://192.168.0.20x/system/reg>

Axum » System configuration » Register informat

Rack configuration			
Slot	Node name	UniqueID	
		Hex	Dec
1	Rack-PWR1	0001:0016:0027	1.22.27
5	Rack-Mic	0001:0002:0073	1.24.73
7	Rack-Line	0001:0001:007C	1.17.7C
10	Rack-DDsrc	0001:0017:007D	1.23.7D
11	Rack-DD	0001:0006:007E	1.6.7E
12	Rack-LineOut	0001:0003:007F	1.3.7F
13	Rack-Monitor	0001:0004:007F	1.4.7F
15	Rack-Hybrid	0001:001D:007F	1.29.7F
16	Rack-DSP	0001:0014:007F	1.20.7F
17	Rack-FW	0001:001E:007F	1.30.7F
18	Rack-CN	0001:001C:007F	1.28.7F

Surface configuration		
Node name	Unique ID	
	Hex	Dec
Axum MambaNet Gateway	0001:0019:007F	1.25.7F
UI-4FBP1..4	0001:0007:007F	1.7.7F
UI-4FBP5..8	0001:0007:007F	1.7.7F
UI-4FBP9..12	0001:0007:007F	1.7.7F
UI-CRMP1..2	0001:0008:007F	1.8.7F
Axum Meters	0001:001A:007F	1.26.7F

- b. The third number in "Unique ID Dec" is the Unique ID number you did write on the boards.

- c. Change the name of the Rack-boards and Fader/CRM units to a more user friendly name:
- i. Rack-Mic, Rack-Line, Rack-Dig, Rack-LineOut, Rack-Hybrid, Rack-Mon, Rack-FW, Rack-CN, etc.
 - ii. UI-4FBP1..4, UI-4FBP5..8, UI-4FBP9..12, etc.
 - iii. Axum Meters1, Axum Meters2

- d. Now Generate Sources.

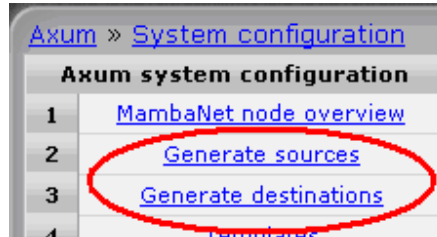

- e. Set Mic Sources left and right to the same slot-source (Left source = Right source) and setup the missing Mic-Inputs.
Set Hybrid Sources left and right to the same slot-source (Left source = Right source) and setup the missing Hybrid-Inputs.
Set the new Mic and Hybrids on the correct position, and check / modify the names. (click on number at the Left).

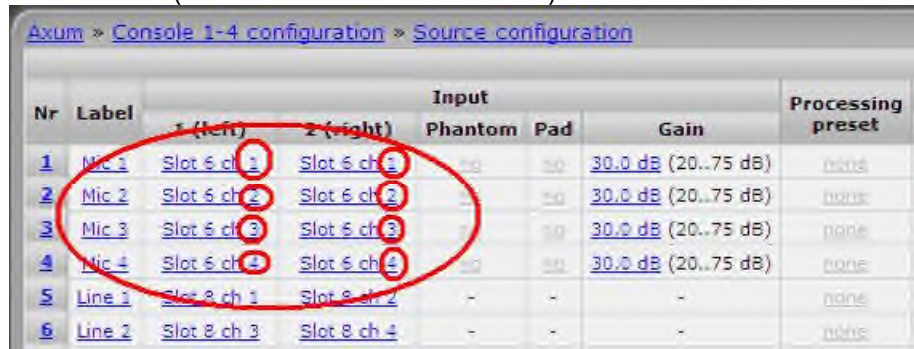

Axum » Console 1-4 configuration » Source configuration

Nr	Label	Input		Phantom	Pad	Gain	Processing preset
		1 (left)	2 (right)				
1	Mic 1	Slot 6 ch 1	Slot 6 ch 1	no	no	30.0 dB (20..75 dB)	none
2	Mic 2	Slot 6 ch 2	Slot 6 ch 2	no	no	30.0 dB (20..75 dB)	none
3	Mic 3	Slot 6 ch 3	Slot 6 ch 3	no	no	30.0 dB (20..75 dB)	none
4	Mic 4	Slot 6 ch 4	Slot 6 ch 4	no	no	30.0 dB (20..75 dB)	none
5	Line 1	Slot 8 ch 1	Slot 8 ch 2	-	-	-	none
6	Line 2	Slot 8 ch 3	Slot 8 ch 4	-	-	-	none

- f. Generate destinations. Check and modify the names.



Axum » Console 1-4 configuration » Destination configuration

Nr	Label	Output 1		
		1 (left)	2 (right)	Level
1	Line Out1 1	Slot 11 ch 1	Slot 11 ch 2	-
2	Line Out1 2	Slot 11 ch 3	Slot 11 ch 4	-
3	Line Out1 3	Slot 11 ch 5	Slot 11 ch 6	-
4	Line Out1 4	Slot 11 ch 7	Slot 11 ch 8	-
5	CRM Speakers	Slot 13 ch 1	Slot 13 ch 2	-
6	Studio Speakers	Slot 13 ch 3	Slot 13 ch 4	-
7	CRM Phones	Slot 13 ch 5	Slot 13 ch 6	-
8	Studio Phones	Slot 13 ch 7	Slot 13 ch 8	-
9	CRM 1	Slot 18 ch 1	Slot 18 ch 2	-



Global configuration

g. Setup and check IP/Clock configuration

[Axum](#) » [Console 1-4 configuration](#) » [IP/Clock configuration](#)

IP <i>(effective after reboot)</i>	
Address	192.168.0.200
Subnet mask:	255.255.255.0
Gateway	192.168.0.1
DNS server	192.168.0.1

Engine MambaNet servers <i>(effective after reboot)</i>		
	Enable	Address
Ethernet	<input type="checkbox"/>	eth0 - 00:18:7D:05:0B:D5
UDP/IP	<input checked="" type="checkbox"/>	34848 <small>default port is 34848</small>
TCP/IP	<input checked="" type="checkbox"/>	34848 <small>default port is 34848</small>

Clock <i>(effective after reboot)</i>	
Current	Thu Mar 31 22:56:32 CST 2011 212.178.112.106 stratum: 2
time zone	Europe/Amsterdam
NTP Servers	0.pool.ntp.org 1.pool.ntp.org 2.pool.ntp.org NMEA GPS on USB (/dev/ttyUSB0) 0.0.0.0 prefer iburst
Set date/time	

h. Setup and check Global configuration

If no CobraNet board is installed set the “Clock master” to Intern.

[Axum](#) » [Console 1-4 configuration](#) » [Global configuration](#)

Global configuration	
Samplerate	48.0 kHz
Clock master	Intern
Headroom	20.0 dB
Fader top level	0 dB
Auto momentary	No
Startup state	Programmed defaults

Console information			
	Name	Location	Contact
Console 1	AXUM 1	Weesp	User 1
Console 2	AXUM 2	Amsterdam	User 2
Console 3	AXUM 3	Utrecht	User 3
Console 4	AXUM 4	Rotterdam	User 4



7. Buss configuration

a. Setup and check Mix buss configuration

[Axum](#) » [Console 1-4 configuration](#) » [Buss configuration](#)

Buss configuration												
Buss	Label	2 Mono busses	Master Pre/Post			Master		Interlock	Exclusive	Buss reset by module active	Console	
			Module on	Module level	Module balance	Level	State					
1/2	Prog	no	Post	Post	Post	0.0 dB	On	no	no	no	1	
3/4	Sub	no	Post	Post	Post	0.0 dB	On	no	no	no	1	
5/6	Aux1	no	Post	Post	Post	0.0 dB	On	no	no	no	1	
7/8	Aux2	no	Post	Post	Post	0.0 dB	On	no	no	no	1	
9/10	Aux3	no	Post	Post	Post	0.0 dB	On	no	no	no	1	
11/12	Aux4	no	Post	Post	Post	0.0 dB	On	no	no	no	1	
13/14	Dump	no	Post	Post	Post	0.0 dB	On	no	Dump/Rec	no	1	
15/16	PFL	no	Pre	Pre	Pre	0.0 dB	On	no	Comm technician	yes	1	
17/18	17/18	no	Post	Post	Post	0.0 dB	On	no	no	no	2	
19/20	19/20	no	Post	Post	Post	0.0 dB	On	no	no	no	2	
21/22	21/22	no	Post	Post	Post	0.0 dB	On	no	no	no	2	
23/24	23/24	no	Post	Post	Post	0.0 dB	On	no	no	no	2	
25/26	25/26	no	Post	Post	Post	0.0 dB	On	no	no	no	3	
27/28	27/28	no	Post	Post	Post	0.0 dB	On	no	no	no	3	
29/30	29/30	no	Post	Post	Post	0.0 dB	On	no	no	no	4	
31/32	31/32	no	Post	Post	Post	0.0 dB	On	no	no	no	4	

b. Setup and check Monitor buss configuration

[Axum](#) » [Console 1-4 configuration](#) » [Monitor buss configuration](#)

Monitor buss configuration																						
Nr.	Label	Interlock	Default selection	Automatic switching																Dim level	Console	
				1	2	3	4	5	6	7	8	9	0	1	2	3	4	5	6			
1	CRM buss	yes	Prog	<input type="checkbox"/>	<input type="checkbox"/>	<input type="checkbox"/>	<input type="checkbox"/>	<input type="checkbox"/>	<input type="checkbox"/>	<input type="checkbox"/>	<input type="checkbox"/>	<input type="checkbox"/>	<input type="checkbox"/>	<input type="checkbox"/>	<input type="checkbox"/>	<input type="checkbox"/>	<input type="checkbox"/>	<input type="checkbox"/>	<input type="checkbox"/>	-20.0 dB	1	
2	Studio buss	yes	Prog	<input type="checkbox"/>	<input type="checkbox"/>	<input type="checkbox"/>	<input type="checkbox"/>	<input type="checkbox"/>	<input type="checkbox"/>	<input type="checkbox"/>	<input type="checkbox"/>	<input type="checkbox"/>	<input type="checkbox"/>	<input type="checkbox"/>	<input type="checkbox"/>	<input type="checkbox"/>	<input type="checkbox"/>	<input type="checkbox"/>	<input type="checkbox"/>	<input type="checkbox"/>	-20.0 dB	1
3	Mon 3	yes	Prog	<input type="checkbox"/>	<input type="checkbox"/>	<input type="checkbox"/>	<input type="checkbox"/>	<input type="checkbox"/>	<input type="checkbox"/>	<input type="checkbox"/>	<input type="checkbox"/>	<input type="checkbox"/>	<input type="checkbox"/>	<input type="checkbox"/>	<input type="checkbox"/>	<input type="checkbox"/>	<input type="checkbox"/>	<input type="checkbox"/>	<input type="checkbox"/>	<input type="checkbox"/>	-20.0 dB	2
4	Mon 4	yes	Prog	<input type="checkbox"/>	<input type="checkbox"/>	<input type="checkbox"/>	<input type="checkbox"/>	<input type="checkbox"/>	<input type="checkbox"/>	<input type="checkbox"/>	<input type="checkbox"/>	<input type="checkbox"/>	<input type="checkbox"/>	<input type="checkbox"/>	<input type="checkbox"/>	<input type="checkbox"/>	<input type="checkbox"/>	<input type="checkbox"/>	<input type="checkbox"/>	<input type="checkbox"/>	-20.0 dB	3
5	Mon 5	yes	Prog	<input type="checkbox"/>	<input type="checkbox"/>	<input type="checkbox"/>	<input type="checkbox"/>	<input type="checkbox"/>	<input type="checkbox"/>	<input type="checkbox"/>	<input type="checkbox"/>	<input type="checkbox"/>	<input type="checkbox"/>	<input type="checkbox"/>	<input type="checkbox"/>	<input type="checkbox"/>	<input type="checkbox"/>	<input type="checkbox"/>	<input type="checkbox"/>	<input type="checkbox"/>	-20.0 dB	4
6	Mon 6	yes	Prog	<input type="checkbox"/>	<input type="checkbox"/>	<input type="checkbox"/>	<input type="checkbox"/>	<input type="checkbox"/>	<input type="checkbox"/>	<input type="checkbox"/>	<input type="checkbox"/>	<input type="checkbox"/>	<input type="checkbox"/>	<input type="checkbox"/>	<input type="checkbox"/>	<input type="checkbox"/>	<input type="checkbox"/>	<input type="checkbox"/>	<input type="checkbox"/>	<input type="checkbox"/>	-20.0 dB	4
7	Mon 7	yes	Prog	<input type="checkbox"/>	<input type="checkbox"/>	<input type="checkbox"/>	<input type="checkbox"/>	<input type="checkbox"/>	<input type="checkbox"/>	<input type="checkbox"/>	<input type="checkbox"/>	<input type="checkbox"/>	<input type="checkbox"/>	<input type="checkbox"/>	<input type="checkbox"/>	<input type="checkbox"/>	<input type="checkbox"/>	<input type="checkbox"/>	<input type="checkbox"/>	<input type="checkbox"/>	-20.0 dB	4
8	Mon 8	yes	Prog	<input type="checkbox"/>	<input type="checkbox"/>	<input type="checkbox"/>	<input type="checkbox"/>	<input type="checkbox"/>	<input type="checkbox"/>	<input type="checkbox"/>	<input type="checkbox"/>	<input type="checkbox"/>	<input type="checkbox"/>	<input type="checkbox"/>	<input type="checkbox"/>	<input type="checkbox"/>	<input type="checkbox"/>	<input type="checkbox"/>	<input type="checkbox"/>	<input type="checkbox"/>	-20.0 dB	4
9	Mon 9	yes	Prog	<input type="checkbox"/>	<input type="checkbox"/>	<input type="checkbox"/>	<input type="checkbox"/>	<input type="checkbox"/>	<input type="checkbox"/>	<input type="checkbox"/>	<input type="checkbox"/>	<input type="checkbox"/>	<input type="checkbox"/>	<input type="checkbox"/>	<input type="checkbox"/>	<input type="checkbox"/>	<input type="checkbox"/>	<input type="checkbox"/>	<input type="checkbox"/>	<input type="checkbox"/>	-20.0 dB	4
10	Mon 10	yes	Prog	<input type="checkbox"/>	<input type="checkbox"/>	<input type="checkbox"/>	<input type="checkbox"/>	<input type="checkbox"/>	<input type="checkbox"/>	<input type="checkbox"/>	<input type="checkbox"/>	<input type="checkbox"/>	<input type="checkbox"/>	<input type="checkbox"/>	<input type="checkbox"/>	<input type="checkbox"/>	<input type="checkbox"/>	<input type="checkbox"/>	<input type="checkbox"/>	<input type="checkbox"/>	-20.0 dB	4
11	Mon 11	yes	Prog	<input type="checkbox"/>	<input type="checkbox"/>	<input type="checkbox"/>	<input type="checkbox"/>	<input type="checkbox"/>	<input type="checkbox"/>	<input type="checkbox"/>	<input type="checkbox"/>	<input type="checkbox"/>	<input type="checkbox"/>	<input type="checkbox"/>	<input type="checkbox"/>	<input type="checkbox"/>	<input type="checkbox"/>	<input type="checkbox"/>	<input type="checkbox"/>	<input type="checkbox"/>	-20.0 dB	4
12	Mon 12	yes	Prog	<input type="checkbox"/>	<input type="checkbox"/>	<input type="checkbox"/>	<input type="checkbox"/>	<input type="checkbox"/>	<input type="checkbox"/>	<input type="checkbox"/>	<input type="checkbox"/>	<input type="checkbox"/>	<input type="checkbox"/>	<input type="checkbox"/>	<input type="checkbox"/>	<input type="checkbox"/>	<input type="checkbox"/>	<input type="checkbox"/>	<input type="checkbox"/>	<input type="checkbox"/>	-20.0 dB	4
13	Mon 13	yes	Prog	<input type="checkbox"/>	<input type="checkbox"/>	<input type="checkbox"/>	<input type="checkbox"/>	<input type="checkbox"/>	<input type="checkbox"/>	<input type="checkbox"/>	<input type="checkbox"/>	<input type="checkbox"/>	<input type="checkbox"/>	<input type="checkbox"/>	<input type="checkbox"/>	<input type="checkbox"/>	<input type="checkbox"/>	<input type="checkbox"/>	<input type="checkbox"/>	<input type="checkbox"/>	-20.0 dB	4
14	Mon 14	yes	Prog	<input type="checkbox"/>	<input type="checkbox"/>	<input type="checkbox"/>	<input type="checkbox"/>	<input type="checkbox"/>	<input type="checkbox"/>	<input type="checkbox"/>	<input type="checkbox"/>	<input type="checkbox"/>	<input type="checkbox"/>	<input type="checkbox"/>	<input type="checkbox"/>	<input type="checkbox"/>	<input type="checkbox"/>	<input type="checkbox"/>	<input type="checkbox"/>	<input type="checkbox"/>	-20.0 dB	4
15	Mon 15	yes	Prog	<input type="checkbox"/>	<input type="checkbox"/>	<input type="checkbox"/>	<input type="checkbox"/>	<input type="checkbox"/>	<input type="checkbox"/>	<input type="checkbox"/>	<input type="checkbox"/>	<input type="checkbox"/>	<input type="checkbox"/>	<input type="checkbox"/>	<input type="checkbox"/>	<input type="checkbox"/>	<input type="checkbox"/>	<input type="checkbox"/>	<input type="checkbox"/>	<input type="checkbox"/>	-20.0 dB	4
16	Mon 16	yes	Prog	<input type="checkbox"/>	<input type="checkbox"/>	<input type="checkbox"/>	<input type="checkbox"/>	<input type="checkbox"/>	<input type="checkbox"/>	<input type="checkbox"/>	<input type="checkbox"/>	<input type="checkbox"/>	<input type="checkbox"/>	<input type="checkbox"/>	<input type="checkbox"/>	<input type="checkbox"/>	<input type="checkbox"/>	<input type="checkbox"/>	<input type="checkbox"/>	<input type="checkbox"/>	-20.0 dB	4



8. Hardware settings

- a. Setup the UI configuration by import the correct setup and offset.**

Axum » Console 1-4 configuration » Surface configuration

Surface configuration							
0001:0019:0011 (Axum MambaNet Gateway)							
MambaNet Address	Node name	Default	Config	Settings			User level
00000021	UI-4FBP1..4	4	88	configure »	import	export	Console 1
00000022	UI-4FBP5..8	4	88	configure »	import	export	Console 1
00000023	UI-4FBP9..12	4	88	configure »	UI-4F Dmp/B/Prg/Sb/PFL/On/S/S (4/88)	Offset 4	Import
00000024	UI-CRMP1..2	0	64	configure »	import	export	Console 1
00000026	Axum Meters	0	130	configure »	import	export	Console 1

It is also possible to replace a board by the MambaNet configuration page. In this page you can replace a not mounted board (removed) by a new one of the same type and software revision. You give the new board the MambaNet address of the removed on.

Axum » System configuration » MambaNet configuration

MambaNet configuration									
Address	Unique ID	Node name	Engine	Parent	User level	Default	Config	Objects	
00000001	0001:0016:0027	Rack-PWR1	00000000	0001:000C:0014	None	0	0	6	↕
00000002	0001:0002:003E	Rack-MICAD	00000000	0001:000C:0014	None	0	0	100	↕
00000003	0001:0002:0031	Rack-Mic	00000000	0001:000C:0014	None	8	36	100	⊗
00000005	0001:0001:0000	Rack-MICAD (0001:0002:003E)	000	0001:000C:0014	None	0	16	108	↕
00000007	0001:0017:0000	Rack-MICAD (0001:0002:003E)	000	0001:000C:0014	None	0	96	252	↕
00000008	0001:0006:0002	Rack-DD	00000000	0001:000C:0014	None	0	96	254	↕
00000009	0001:0003:0024	Rack-LineOut	00000000	0001:000C:0014	None	0	88	212	↕

After import or swapping UniqueID's you have to check the configuration and adjust the wrong or not set functions. Especially the TB setup must be checked.



UI-4Fader default D&R setup:

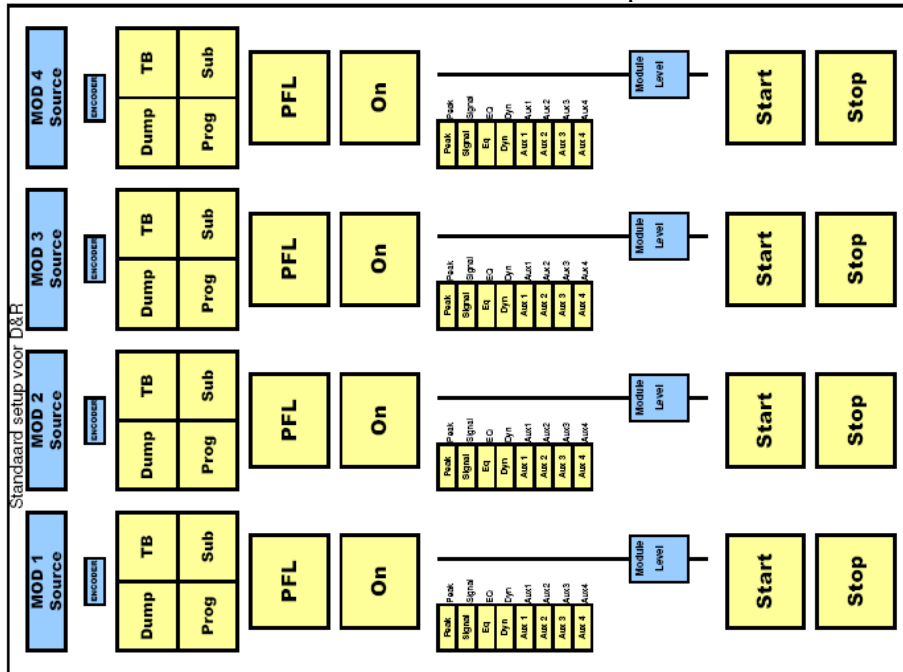

UI-4Fader Broadcast partners setup:

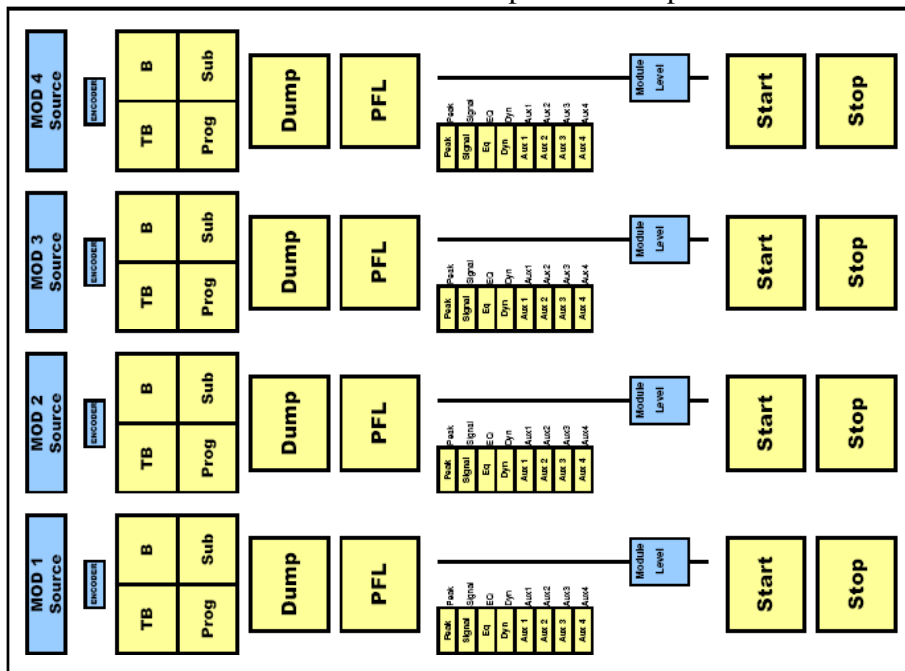



UI-CRM default D&R setup:

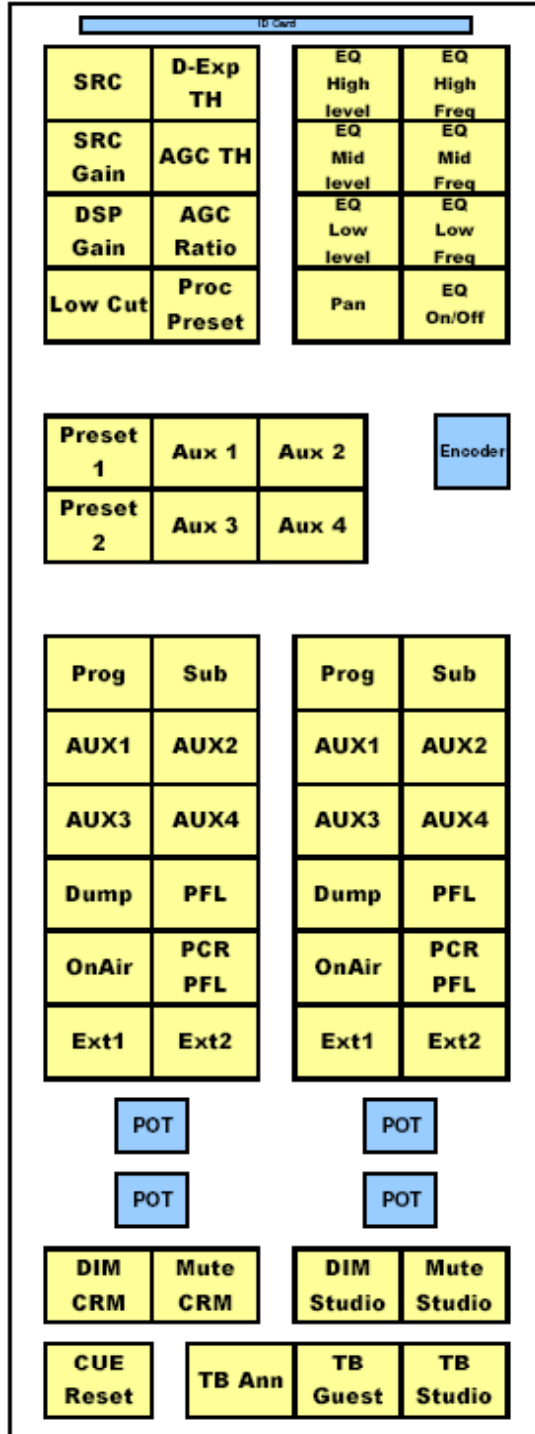



Setup the Rack configuration by import the correct setup and offset.

Axum » Console 1-4 configuration » Rack configuration

Rack configuration										
Slot	WC	MambaNet Address	Node name	Inputs	Outputs	Default	Config		Settings	User level
1		00000001	Rack-PWR1	0	0	0	0	configure >	no import data no export data	None
5		00000003	Rack-Mic	4	0	8	36	configure >	import export	None
7		00000005	Rack-Line	8	0	0	16	configure >	import export	None
10		00000007	Rack-DDsrc	8	8	0	96	configure >	Rack-Line-In (0/16) Offset 0	Import
11	<input type="radio"/>	00000008	Rack-DD	8	8	0	96	configure >	Rack-Line-In (0/16)	None
12		00000009	Rack-LineOut	0	8	0	88	configure >	import export	None
13		0000000B	Rack-Monitor	0	8	8	104	configure >	import export	None
15		00000014	Rack-Hybrid	4	8	0	76	configure >	import export	None
16		0000000D	Rack-DSP	0	0	0	0	configure >	no import data no export data	None
17		00000012	Rack-FW	16	16	32	160	configure >	import export	None
18	<input type="radio"/>	00000010	Rack-CN	16	16	0	160	configure >	import export	None
	<input checked="" type="radio"/>	00000019	Axum MambaNet Gateway							

It is also possible to replace a board by the MambaNet configuration page.
In this page you can replace a not mounted board (removed) by a new one of the same type and software revision.

You give the new board the MambaNet address of the removed on.

Axum » System configuration » MambaNet configuration

MambaNet configuration									
Address	Unique ID	Node name	Engine	Parent	User level	Default	Config	Objects	
00000001	0001:0016:0027	Rack-PWR1	00000000	0001:000C:0014	None	0	0	6	↕
00000002	0001:0002:003E	Rack-MICAD	00000000	0001:000C:0014	None	0	0	100	↕
00000003	0001:0002:0031	Rack-Mic	00000000	0001:000C:0014	None	8	36	100	✕
00000005	0001:0001:0031	Rack-MICAD (0001:0002:003E)	00000000	0001:000C:0014	None	0	16	108	↕
00000007	0001:0017:0031	Rack-MICAD (0001:0002:003E)	00000000	0001:000C:0014	None	0	96	252	↕
00000008	0001:0006:0002	Rack-DD	00000000	0001:000C:0014	None	0	96	254	↕
00000009	0001:0003:0024	Rack-LineOut	00000000	0001:000C:0014	None	0	88	212	↕

After import or swapping UniqueID's you have to check the configuration and adjust the wrong or not set functions

If CobraNet is connected set WC to CobraNet.



c. Setup and check Destination configuration

[Axum](#) » [Console 1-4 configuration](#) » [Destination configuration](#)

Nr	Label	Output 1		Level	Default signal		N-1 from	
		1 (left)	2 (right)		From	Routing		
1	DDsrc 1	Slot 10 ch 1	Slot 10 ch 2	-	Prog	stereo	none	<input type="checkbox"/>
2	DDsrc 2	Slot 10 ch 3	Slot 10 ch 4	-	Sub	stereo	none	<input type="checkbox"/>
3	DDsrc 3	Slot 10 ch 5	Slot 10 ch 6	-	Dump	stereo	none	<input type="checkbox"/>
4	DDsrc 4	Slot 10 ch 7	Slot 10 ch 8	-	Aux1	stereo	none	<input type="checkbox"/>
5	DD 5	Slot 11 ch 1	Slot 11 ch 2	-	Prog	stereo	none	<input type="checkbox"/>
6	DD 6	Slot 11 ch 3	Slot 11 ch 4	-	Sub	stereo	none	<input type="checkbox"/>
7	DD 7	Slot 11 ch 5	Slot 11 ch 6	-	Dump	stereo	none	<input type="checkbox"/>
8	DD 8	Slot 11 ch 7	Slot 11 ch 8	-	Aux1	stereo	none	<input type="checkbox"/>
9	LineOut 1	Slot 12 ch 1	Slot 12 ch 2	-	Prog	stereo	none	<input type="checkbox"/>
10	LineOut 2	Slot 12 ch 3	Slot 12 ch 4	-	Sub	stereo	none	<input type="checkbox"/>
11	LineOut 3	Slot 12 ch 5	Slot 12 ch 6	-	Dump	stereo	none	<input type="checkbox"/>
12	LineOut 4	Slot 12 ch 7	Slot 12 ch 8	-	Aux1	stereo	none	<input type="checkbox"/>
13	CRM Speakers	Slot 13 ch 1	Slot 13 ch 2	-	CRM buss	stereo	none	<input type="checkbox"/>
14	Studio Speakers	Slot 13 ch 3	Slot 13 ch 4	-	Studio buss	stereo	none	<input type="checkbox"/>
15	CRM Phones	Slot 13 ch 5	Slot 13 ch 6	-	CRM buss	stereo	none	<input type="checkbox"/>
16	Studio Phones	Slot 13 ch 7	Slot 13 ch 8	-	Studio buss	stereo	none	<input type="checkbox"/>
17	Hybrid 1	Slot 15 ch 1	Slot 15 ch 2	-	none	mono	Hybrid 1	<input type="checkbox"/>
18	Hybrid 2	Slot 15 ch 3	Slot 15 ch 4	-	none	mono	Hybrid 2	<input type="checkbox"/>
19	Hybrid 3	Slot 15 ch 5	Slot 15 ch 6	-	none	mono	Hybrid 3	<input type="checkbox"/>
20	Hybrid 4	Slot 15 ch 7	Slot 15 ch 8	-	none	mono	Hybrid 4	<input type="checkbox"/>
21	FW 1	Slot 17 ch 1	Slot 17 ch 2	-	Prog	stereo	none	<input type="checkbox"/>

d. Setup and check Talkback configuration

[Axum](#) » [Console 1-4 configuration](#) » [Talkback configuration](#)

Talkback configuration	
Talkback 1	Mic 1
Talkback 2	Mic 2
Talkback 3	Mic 3
Talkback 4	Mic 4
Talkback 5	none
Talkback 6	none
Talkback 7	none



10. Module settings

a. Setup and check Processing presets

The screenshot shows two panels from the software interface. The left panel, titled 'Processing preset', lists seven presets with their labels and settings. The right panel, titled 'Settings for preset: DJ Prst', shows the specific settings for the selected preset.

Nr	Label	Settings	
1	DJ Prst	Configure	»Copy to new preset
2	Ann Prst	Configure	»Copy to new preset
3	Gst Prst	Configure	»Copy to new preset
4	Hybrid	Configure	»Copy to new preset
5	No Proc	Configure	»Copy to new preset
6	Eq On	Configure	»Copy to new preset
7	Low Cut	Configure	»Copy to new preset

	Override module	Preset state	Preset value
Digital gain	yes	-	0.0 dB
Low cut	yes	on	65 Hz
Insert	yes	off	-
Phase	yes	off	Both
Mono	yes	off	Mono
EQ	yes	on	EQ settings »
Dynamics	yes	on	Dyn settings »
Module	no	off	Off

b. Setup and check Module assignment

The screenshot shows the 'Module assignment' screen. It features a grid where modules are assigned to 32 channels. The 'Console' row shows the assigned module for each channel. Below the grid, there is a 'generate' button and a note about the assignment process.

	1	2	3	4	5	6	7	8	9	10	11	12	13	14	15	16	17	18	19	20	21	22	23	24	25	26	27	28	29	30	31	32	
Console	1	1	1	1	1	1	1	1	1	1	1	1	1	1	1	1	2	2	2	2	2	2	2	3	3	3	3	4	4	4	4		
Prog	Y	Y	Y	Y	Y	Y	Y	Y	Y	Y	Y	Y	Y	Y	Y	Y																	
Sub	Y	Y	Y	Y	Y	Y	Y	Y	Y	Y	Y	Y	Y	Y	Y	Y																	
Aux1	Y	Y	Y	Y	Y	Y	Y	Y	Y	Y	Y	Y	Y	Y	Y	Y																	
Aux2	Y	Y	Y	Y	Y	Y	Y	Y	Y	Y	Y	Y	Y	Y	Y	Y																	
Aux3	Y	Y	Y	Y	Y	Y	Y	Y	Y	Y	Y	Y	Y	Y	Y	Y																	
Aux4	Y	Y	Y	Y	Y	Y	Y	Y	Y	Y	Y	Y	Y	Y	Y	Y																	
Dump	Y	Y	Y	Y	Y	Y	Y	Y	Y	Y	Y	Y	Y	Y	Y	Y																	
PFL	Y	Y	Y	Y	Y	Y	Y	Y	Y	Y	Y	Y	Y	Y	Y	Y																	
17/18																	Y	Y	Y	Y	Y	Y	Y	Y									
19/20																	Y	Y	Y	Y	Y	Y	Y	Y									
21/22																	Y	Y	Y	Y	Y	Y	Y	Y									
23/24																	Y	Y	Y	Y	Y	Y	Y	Y									
25/26																									Y	Y	Y	Y					
27/28																									Y	Y	Y	Y					
29/30																													Y	Y	Y	Y	
31/32																													Y	Y	Y	Y	



c. Setup and check Module configuration

[Axum](#) » [Console 1-4 configuration](#) » [Module configuration](#)

Page: [1](#) [2](#) [3](#) [4](#)

Module overview									
	Module 1	Module 2	Module 3	Module 4	Module 5	Module 6	Module 7	Module 8	
Console	1	1	1	1	1	1	1	1	
Preset 1	A	Mic 1 (DJ Prst)	Mic 2 (Ann Prst)	Mic 3 (Ann Prst)	Mic 4 (Ann Prst)	Line 1 (No Proc)	Line 2 (No Proc)	Line 3 (No Proc)	Line 4 (No Proc)
	B	none (Ann Prst)	none (Gst Prst)	none (Gst Prst)	none (Gst Prst)	none (Eq On)	none (Eq On)	none (Eq On)	none (Eq On)
Preset 2	A	Hybrid 1 (Hybrid)	Hybrid 2 (Hybrid)	Hybrid 3 (Hybrid)	Hybrid 4 (Hybrid)	FW 1 (No Proc)	FW 2 (No Proc)	FW 3 (No Proc)	FW 4 (No Proc)
	B	none	none	none	none	none (Eq On)	none (Eq On)	none (Eq On)	none (Eq On)
Preset 3	A	none	none	none	none	none	none	none	
	B	none	none	none	none	none	none	none	
Preset 4	A	none	none	none	none	none	none	none	
	B	none	none	none	none	none	none	none	
Processing	none	none	none	none	none	none	none	none	
Routing	none	none	none	none	none	none	none	none	
	Module 9	Module 10	Module 11	Module 12	Module 13	Module 14	Module 15	Module 16	
Console	1	1	1	1	1	1	1	1	
Preset 1	A	DDsrc 1 (No Proc)	DDsrc 2 (No Proc)	DDsrc 3 (No Proc)	DDsrc 4 (No Proc)	none (No Proc)	none (No Proc)	none (No Proc)	none (No Proc)
	B	none	none	none	none	none	none	none	none
Preset 2	A	FW 5 (No Proc)	FW 6 (No Proc)	FW 7 (No Proc)	FW 8 (No Proc)	none (No Proc)	none (No Proc)	none (No Proc)	none (No Proc)
	B	none	none	none	none	none	none	none	none
Preset 3	A	none	none	none	none	none	none	none	
	B	none	none	none	none	none	none	none	
Preset 4	A	none	none	none	none	none	none	none	
	B	none	none	none	none	none	none	none	
Processing	none	none	none	none	none	none	none	none	
Routing	none	none	none	none	none	none	none	none	
	Module 17	Module 18	Module 19	Module 20	Module 21	Module 22	Module 23	Module 24	
Console	2	2	2	2	2	2	2	2	
Preset 1	A	none	none	none	none	none	none	none	
	B	none	none	none	none	none	none	none	
Preset 2	A	none	none	none	none	none	none	none	
	B	none	none	none	none	none	none	none	
Preset 3	A	none	none	none	none	none	none	none	
	B	none	none	none	none	none	none	none	



11. Console settings

a. Setup and check Mix/monitor buss presets

axum » Console 1-4 configuration » Mix/monitor buss presets » Buss preset 'Monitor Default Prst

Mix/monitor buss presets			Mix buss preset - Monitor Default Prst					Buss preset 'Monitor Default Prst							
Nr	Label	Settings	Buss	Console	Use	Master Level	Master State	Console	CRM buss 1		Studio buss 1		Mon 3 2		M
						dB			Use	State	Use	State	Use	State	Use
1	Monitor Default Prst	Configure	Prog	1	no	0.0	on	Prog	yes	on	yes	on	no	off	no
2	Monitor Prst 2	Configure	Sub	1	no	0.0	on	Sub	yes	off	yes	off	no	off	no
3	Monitor VoiceTrack On Prst	Configure	Aux1	1	no	0.0	on	Aux1	yes	off	yes	off	no	off	no
4	Monitor VoiceTrack Off Prst	Configure	Aux2	1	no	0.0	on	Aux2	yes	off	yes	off	no	off	no
5	Reset Buss/CRM/Studio 1	Configure	Aux3	1	no	0.0	on	Aux3	yes	off	yes	off	no	off	no
6	Reset Buss/CRM/Studio 2	Configure	Aux4	1	no	0.0	on	Aux4	yes	off	yes	off	no	off	no
			Dump	1	no	0.0	on	Dump	yes	off	yes	off	no	off	no
			PFL	1	no	0.0	on	PFL	yes	off	yes	off	no	off	no
			17/18	2	no	0.0	on	17/18	yes	off	yes	off	no	off	no
			19/20	2	no	0.0	on	19/20	yes	off	yes	off	no	off	no
			21/22	2	no	0.0	on	21/22	yes	off	yes	off	no	off	no
			23/24	2	no	0.0	on	23/24	yes	off	yes	off	no	off	no
			25/26	3	no	0.0	on	25/26	yes	off	yes	off	no	off	no
			27/28	3	no	0.0	on	27/28	yes	off	yes	off	no	off	no
			29/30	4	no	0.0	on	29/30	yes	off	yes	off	no	off	no
			31/32	4	no	0.0	on	31/32	yes	off	yes	off	no	off	no
								Ext 1	yes	off	yes	off	no	off	no
								Ext 2	yes	off	yes	off	no	off	no
								Ext 3	yes	off	yes	off	no	off	no
								Ext 4	yes	off	yes	off	no	off	no
								Ext 5	yes	off	yes	off	no	off	no
								Ext 6	yes	off	yes	off	no	off	no
								Ext 7	yes	off	yes	off	no	off	no
								Ext 8	yes	off	yes	off	no	off	no

Create new buss preset

b. Setup and check Console presets

axum » Console 1-4 configuration » Console presets

Console presets										
Nr	Label	Console				Module preset	Mix/monitor buss preset	Recall time		
		1	2	3	4			safe	forced	
1	Consol 1 Prst 1a	y	n	n	n	1A	Monitor Default Prst	0 Sec	3 Sec	⊗
2	Consol 1 Prst 1b	y	n	n	n	1B	Monitor Default Prst	0 Sec	3 Sec	⊗
3	Consol 1 Prst 2a	y	n	n	n	2A	Monitor Default Prst	0 Sec	3 Sec	⊗
4	Consol 1 Prst 2b	y	n	n	n	2B	Monitor Default Prst	0 Sec	3 Sec	⊗
5	Consol 1 Prst 3a	y	n	n	n	3A	Monitor Default Prst	0 Sec	3 Sec	⊗
6	Consol 1 Prst 3b	y	n	n	n	3B	Monitor Default Prst	0 Sec	3 Sec	⊗
7	Consol 1 Prst 4a	y	n	n	n	4A	Monitor Default Prst	0 Sec	3 Sec	⊗
8	Consol 1 Prst 4b	y	n	n	n	4B	Monitor Default Prst	0 Sec	3 Sec	⊗
9	Consol 1 Default	y	n	n	n	1A	Monitor Default Prst	0 Sec	3 Sec	⊗
10	VoiceTrack CRM1 On	y	n	n	n	None	Monitor VoiceTrack On Prst	0 Sec	0 Sec	⊗
11	VoiceTrack CRM1 Off	y	n	n	n	None	Monitor VoiceTrack Off Prst	0 Sec	0 Sec	⊗

Create new console preset



12. Security settings

a. Setup and check Source pools

Axum » Console 1-4 configuration » Source pools										
Source pool										
Nr	Type	Label	Console 1		Console 2		Console 3		Console 4	
			A	B	A	B	A	B	A	B
1	none	mute	<input type="checkbox"/>	<input type="checkbox"/>	<input type="checkbox"/>	<input type="checkbox"/>	<input type="checkbox"/>	<input type="checkbox"/>	<input type="checkbox"/>	<input type="checkbox"/>
2	none	none	<input type="checkbox"/>	<input type="checkbox"/>	<input type="checkbox"/>	<input type="checkbox"/>	<input type="checkbox"/>	<input type="checkbox"/>	<input type="checkbox"/>	<input type="checkbox"/>
3	source	Mic 1	<input checked="" type="checkbox"/>	<input checked="" type="checkbox"/>	<input checked="" type="checkbox"/>	<input checked="" type="checkbox"/>	<input checked="" type="checkbox"/>	<input checked="" type="checkbox"/>	<input checked="" type="checkbox"/>	<input checked="" type="checkbox"/>
4	source	Mic 2	<input checked="" type="checkbox"/>	<input checked="" type="checkbox"/>	<input checked="" type="checkbox"/>	<input checked="" type="checkbox"/>	<input checked="" type="checkbox"/>	<input checked="" type="checkbox"/>	<input checked="" type="checkbox"/>	<input checked="" type="checkbox"/>
5	source	Mic 3	<input checked="" type="checkbox"/>	<input checked="" type="checkbox"/>	<input checked="" type="checkbox"/>	<input checked="" type="checkbox"/>	<input checked="" type="checkbox"/>	<input checked="" type="checkbox"/>	<input checked="" type="checkbox"/>	<input checked="" type="checkbox"/>
6	source	Mic 4	<input checked="" type="checkbox"/>	<input checked="" type="checkbox"/>	<input checked="" type="checkbox"/>	<input checked="" type="checkbox"/>	<input checked="" type="checkbox"/>	<input checked="" type="checkbox"/>	<input checked="" type="checkbox"/>	<input checked="" type="checkbox"/>
7	source	Line 1	<input checked="" type="checkbox"/>	<input checked="" type="checkbox"/>	<input checked="" type="checkbox"/>	<input checked="" type="checkbox"/>	<input checked="" type="checkbox"/>	<input checked="" type="checkbox"/>	<input checked="" type="checkbox"/>	<input checked="" type="checkbox"/>
8	source	Line 2	<input checked="" type="checkbox"/>	<input checked="" type="checkbox"/>	<input checked="" type="checkbox"/>	<input checked="" type="checkbox"/>	<input checked="" type="checkbox"/>	<input checked="" type="checkbox"/>	<input checked="" type="checkbox"/>	<input checked="" type="checkbox"/>
9	source	Line 3	<input checked="" type="checkbox"/>	<input checked="" type="checkbox"/>	<input checked="" type="checkbox"/>	<input checked="" type="checkbox"/>	<input checked="" type="checkbox"/>	<input checked="" type="checkbox"/>	<input checked="" type="checkbox"/>	<input checked="" type="checkbox"/>
10	source	Line 4	<input checked="" type="checkbox"/>	<input checked="" type="checkbox"/>	<input checked="" type="checkbox"/>	<input checked="" type="checkbox"/>	<input checked="" type="checkbox"/>	<input checked="" type="checkbox"/>	<input checked="" type="checkbox"/>	<input checked="" type="checkbox"/>
11	source	DDsrc 1	<input checked="" type="checkbox"/>	<input checked="" type="checkbox"/>	<input checked="" type="checkbox"/>	<input checked="" type="checkbox"/>	<input checked="" type="checkbox"/>	<input checked="" type="checkbox"/>	<input checked="" type="checkbox"/>	<input checked="" type="checkbox"/>
12	source	DDsrc 2	<input checked="" type="checkbox"/>	<input checked="" type="checkbox"/>	<input checked="" type="checkbox"/>	<input checked="" type="checkbox"/>	<input checked="" type="checkbox"/>	<input checked="" type="checkbox"/>	<input checked="" type="checkbox"/>	<input checked="" type="checkbox"/>
13	source	DDsrc 3	<input checked="" type="checkbox"/>	<input checked="" type="checkbox"/>	<input checked="" type="checkbox"/>	<input checked="" type="checkbox"/>	<input checked="" type="checkbox"/>	<input checked="" type="checkbox"/>	<input checked="" type="checkbox"/>	<input checked="" type="checkbox"/>
14	source	DDsrc 4	<input checked="" type="checkbox"/>	<input checked="" type="checkbox"/>	<input checked="" type="checkbox"/>	<input checked="" type="checkbox"/>	<input checked="" type="checkbox"/>	<input checked="" type="checkbox"/>	<input checked="" type="checkbox"/>	<input checked="" type="checkbox"/>
15	source	DD 5	<input checked="" type="checkbox"/>	<input checked="" type="checkbox"/>	<input checked="" type="checkbox"/>	<input checked="" type="checkbox"/>	<input checked="" type="checkbox"/>	<input checked="" type="checkbox"/>	<input checked="" type="checkbox"/>	<input checked="" type="checkbox"/>
16	source	DD 6	<input checked="" type="checkbox"/>	<input checked="" type="checkbox"/>	<input checked="" type="checkbox"/>	<input checked="" type="checkbox"/>	<input checked="" type="checkbox"/>	<input checked="" type="checkbox"/>	<input checked="" type="checkbox"/>	<input checked="" type="checkbox"/>
17	source	DD 7	<input checked="" type="checkbox"/>	<input checked="" type="checkbox"/>	<input checked="" type="checkbox"/>	<input checked="" type="checkbox"/>	<input checked="" type="checkbox"/>	<input checked="" type="checkbox"/>	<input checked="" type="checkbox"/>	<input checked="" type="checkbox"/>
18	source	DD 8	<input checked="" type="checkbox"/>	<input checked="" type="checkbox"/>	<input checked="" type="checkbox"/>	<input checked="" type="checkbox"/>	<input checked="" type="checkbox"/>	<input checked="" type="checkbox"/>	<input checked="" type="checkbox"/>	<input checked="" type="checkbox"/>
19	source	Hybrid 1	<input checked="" type="checkbox"/>	<input checked="" type="checkbox"/>	<input checked="" type="checkbox"/>	<input checked="" type="checkbox"/>	<input checked="" type="checkbox"/>	<input checked="" type="checkbox"/>	<input checked="" type="checkbox"/>	<input checked="" type="checkbox"/>
20	source	Hybrid 2	<input checked="" type="checkbox"/>	<input checked="" type="checkbox"/>	<input checked="" type="checkbox"/>	<input checked="" type="checkbox"/>	<input checked="" type="checkbox"/>	<input checked="" type="checkbox"/>	<input checked="" type="checkbox"/>	<input checked="" type="checkbox"/>
21	source	Hybrid 3	<input checked="" type="checkbox"/>	<input checked="" type="checkbox"/>	<input checked="" type="checkbox"/>	<input checked="" type="checkbox"/>	<input checked="" type="checkbox"/>	<input checked="" type="checkbox"/>	<input checked="" type="checkbox"/>	<input checked="" type="checkbox"/>
22	source	Hybrid 4	<input checked="" type="checkbox"/>	<input checked="" type="checkbox"/>	<input checked="" type="checkbox"/>	<input checked="" type="checkbox"/>	<input checked="" type="checkbox"/>	<input checked="" type="checkbox"/>	<input checked="" type="checkbox"/>	<input checked="" type="checkbox"/>
23	source	FW 1	<input checked="" type="checkbox"/>	<input checked="" type="checkbox"/>	<input checked="" type="checkbox"/>	<input checked="" type="checkbox"/>	<input checked="" type="checkbox"/>	<input checked="" type="checkbox"/>	<input checked="" type="checkbox"/>	<input checked="" type="checkbox"/>
24	source	FW 2	<input checked="" type="checkbox"/>	<input checked="" type="checkbox"/>	<input checked="" type="checkbox"/>	<input checked="" type="checkbox"/>	<input checked="" type="checkbox"/>	<input checked="" type="checkbox"/>	<input checked="" type="checkbox"/>	<input checked="" type="checkbox"/>
25	source	FW 3	<input checked="" type="checkbox"/>	<input checked="" type="checkbox"/>	<input checked="" type="checkbox"/>	<input checked="" type="checkbox"/>	<input checked="" type="checkbox"/>	<input checked="" type="checkbox"/>	<input checked="" type="checkbox"/>	<input checked="" type="checkbox"/>
26	source	FW 4	<input checked="" type="checkbox"/>	<input checked="" type="checkbox"/>	<input checked="" type="checkbox"/>	<input checked="" type="checkbox"/>	<input checked="" type="checkbox"/>	<input checked="" type="checkbox"/>	<input checked="" type="checkbox"/>	<input checked="" type="checkbox"/>
27	source	FW 5	<input checked="" type="checkbox"/>	<input checked="" type="checkbox"/>	<input checked="" type="checkbox"/>	<input checked="" type="checkbox"/>	<input checked="" type="checkbox"/>	<input checked="" type="checkbox"/>	<input checked="" type="checkbox"/>	<input checked="" type="checkbox"/>
28	source	FW 6	<input checked="" type="checkbox"/>	<input checked="" type="checkbox"/>	<input checked="" type="checkbox"/>	<input checked="" type="checkbox"/>	<input checked="" type="checkbox"/>	<input checked="" type="checkbox"/>	<input checked="" type="checkbox"/>	<input checked="" type="checkbox"/>
29	source	FW 7	<input checked="" type="checkbox"/>	<input checked="" type="checkbox"/>	<input checked="" type="checkbox"/>	<input checked="" type="checkbox"/>	<input checked="" type="checkbox"/>	<input checked="" type="checkbox"/>	<input checked="" type="checkbox"/>	<input checked="" type="checkbox"/>
30	source	FW 8	<input checked="" type="checkbox"/>	<input checked="" type="checkbox"/>	<input checked="" type="checkbox"/>	<input checked="" type="checkbox"/>	<input checked="" type="checkbox"/>	<input checked="" type="checkbox"/>	<input checked="" type="checkbox"/>	<input checked="" type="checkbox"/>
31	source	CN 1	<input checked="" type="checkbox"/>	<input checked="" type="checkbox"/>	<input checked="" type="checkbox"/>	<input checked="" type="checkbox"/>	<input checked="" type="checkbox"/>	<input checked="" type="checkbox"/>	<input checked="" type="checkbox"/>	<input checked="" type="checkbox"/>
32	source	CN 2	<input checked="" type="checkbox"/>	<input checked="" type="checkbox"/>	<input checked="" type="checkbox"/>	<input checked="" type="checkbox"/>	<input checked="" type="checkbox"/>	<input checked="" type="checkbox"/>	<input checked="" type="checkbox"/>	<input checked="" type="checkbox"/>
33	source	CN 3	<input checked="" type="checkbox"/>	<input checked="" type="checkbox"/>	<input checked="" type="checkbox"/>	<input checked="" type="checkbox"/>	<input checked="" type="checkbox"/>	<input checked="" type="checkbox"/>	<input checked="" type="checkbox"/>	<input checked="" type="checkbox"/>
34	source	CN 4	<input checked="" type="checkbox"/>	<input checked="" type="checkbox"/>	<input checked="" type="checkbox"/>	<input checked="" type="checkbox"/>	<input checked="" type="checkbox"/>	<input checked="" type="checkbox"/>	<input checked="" type="checkbox"/>	<input checked="" type="checkbox"/>
35	source	CN 5	<input checked="" type="checkbox"/>	<input checked="" type="checkbox"/>	<input checked="" type="checkbox"/>	<input checked="" type="checkbox"/>	<input checked="" type="checkbox"/>	<input checked="" type="checkbox"/>	<input checked="" type="checkbox"/>	<input checked="" type="checkbox"/>
36	source	CN 6	<input checked="" type="checkbox"/>	<input checked="" type="checkbox"/>	<input checked="" type="checkbox"/>	<input checked="" type="checkbox"/>	<input checked="" type="checkbox"/>	<input checked="" type="checkbox"/>	<input checked="" type="checkbox"/>	<input checked="" type="checkbox"/>
37	source	CN 7	<input checked="" type="checkbox"/>	<input checked="" type="checkbox"/>	<input checked="" type="checkbox"/>	<input checked="" type="checkbox"/>	<input checked="" type="checkbox"/>	<input checked="" type="checkbox"/>	<input checked="" type="checkbox"/>	<input checked="" type="checkbox"/>
38	source	CN 8	<input checked="" type="checkbox"/>	<input checked="" type="checkbox"/>	<input checked="" type="checkbox"/>	<input checked="" type="checkbox"/>	<input checked="" type="checkbox"/>	<input checked="" type="checkbox"/>	<input checked="" type="checkbox"/>	<input checked="" type="checkbox"/>
39	buss	Prog	<input type="checkbox"/>	<input checked="" type="checkbox"/>	<input type="checkbox"/>	<input checked="" type="checkbox"/>	<input type="checkbox"/>	<input checked="" type="checkbox"/>	<input type="checkbox"/>	<input checked="" type="checkbox"/>
40	buss	Sub	<input type="checkbox"/>	<input checked="" type="checkbox"/>	<input type="checkbox"/>	<input checked="" type="checkbox"/>	<input type="checkbox"/>	<input checked="" type="checkbox"/>	<input type="checkbox"/>	<input checked="" type="checkbox"/>
41	buss	Aux1	<input type="checkbox"/>	<input checked="" type="checkbox"/>	<input type="checkbox"/>	<input checked="" type="checkbox"/>	<input type="checkbox"/>	<input checked="" type="checkbox"/>	<input type="checkbox"/>	<input checked="" type="checkbox"/>
42	buss	Aux2	<input type="checkbox"/>	<input checked="" type="checkbox"/>	<input type="checkbox"/>	<input checked="" type="checkbox"/>	<input type="checkbox"/>	<input checked="" type="checkbox"/>	<input type="checkbox"/>	<input checked="" type="checkbox"/>
43	buss	Aux3	<input type="checkbox"/>	<input checked="" type="checkbox"/>	<input type="checkbox"/>	<input checked="" type="checkbox"/>	<input type="checkbox"/>	<input checked="" type="checkbox"/>	<input type="checkbox"/>	<input checked="" type="checkbox"/>
44	buss	Aux4	<input type="checkbox"/>	<input checked="" type="checkbox"/>	<input type="checkbox"/>	<input checked="" type="checkbox"/>	<input type="checkbox"/>	<input checked="" type="checkbox"/>	<input type="checkbox"/>	<input checked="" type="checkbox"/>
45	buss	Dump	<input type="checkbox"/>	<input checked="" type="checkbox"/>	<input type="checkbox"/>	<input checked="" type="checkbox"/>	<input type="checkbox"/>	<input checked="" type="checkbox"/>	<input type="checkbox"/>	<input checked="" type="checkbox"/>
46	buss	PFL	<input type="checkbox"/>	<input checked="" type="checkbox"/>	<input type="checkbox"/>	<input checked="" type="checkbox"/>	<input type="checkbox"/>	<input checked="" type="checkbox"/>	<input type="checkbox"/>	<input checked="" type="checkbox"/>
47	buss	17/18	<input type="checkbox"/>	<input checked="" type="checkbox"/>	<input type="checkbox"/>	<input checked="" type="checkbox"/>	<input type="checkbox"/>	<input checked="" type="checkbox"/>	<input type="checkbox"/>	<input checked="" type="checkbox"/>
48	buss	19/20	<input type="checkbox"/>	<input checked="" type="checkbox"/>	<input type="checkbox"/>	<input checked="" type="checkbox"/>	<input type="checkbox"/>	<input checked="" type="checkbox"/>	<input type="checkbox"/>	<input checked="" type="checkbox"/>
49	buss	21/22	<input type="checkbox"/>	<input checked="" type="checkbox"/>	<input type="checkbox"/>	<input checked="" type="checkbox"/>	<input type="checkbox"/>	<input checked="" type="checkbox"/>	<input type="checkbox"/>	<input checked="" type="checkbox"/>
50	buss	23/24	<input type="checkbox"/>	<input checked="" type="checkbox"/>	<input type="checkbox"/>	<input checked="" type="checkbox"/>	<input type="checkbox"/>	<input checked="" type="checkbox"/>	<input type="checkbox"/>	<input checked="" type="checkbox"/>
51	buss	25/26	<input type="checkbox"/>	<input checked="" type="checkbox"/>	<input type="checkbox"/>	<input checked="" type="checkbox"/>	<input type="checkbox"/>	<input checked="" type="checkbox"/>	<input type="checkbox"/>	<input checked="" type="checkbox"/>
52	buss	27/28	<input type="checkbox"/>	<input checked="" type="checkbox"/>	<input type="checkbox"/>	<input checked="" type="checkbox"/>	<input type="checkbox"/>	<input checked="" type="checkbox"/>	<input type="checkbox"/>	<input checked="" type="checkbox"/>
53	buss	29/30	<input type="checkbox"/>	<input checked="" type="checkbox"/>	<input type="checkbox"/>	<input checked="" type="checkbox"/>	<input type="checkbox"/>	<input checked="" type="checkbox"/>	<input type="checkbox"/>	<input checked="" type="checkbox"/>
54	buss	31/32	<input type="checkbox"/>	<input checked="" type="checkbox"/>	<input type="checkbox"/>	<input checked="" type="checkbox"/>	<input type="checkbox"/>	<input checked="" type="checkbox"/>	<input type="checkbox"/>	<input checked="" type="checkbox"/>
55	monitor buss	CRM buss	<input type="checkbox"/>	<input type="checkbox"/>	<input type="checkbox"/>	<input type="checkbox"/>	<input type="checkbox"/>	<input type="checkbox"/>	<input type="checkbox"/>	<input type="checkbox"/>
56	monitor buss	Studio buss	<input type="checkbox"/>	<input type="checkbox"/>	<input type="checkbox"/>	<input type="checkbox"/>	<input type="checkbox"/>	<input type="checkbox"/>	<input type="checkbox"/>	<input type="checkbox"/>
57	monitor buss	Mon 3	<input type="checkbox"/>	<input type="checkbox"/>	<input type="checkbox"/>	<input type="checkbox"/>	<input type="checkbox"/>	<input type="checkbox"/>	<input type="checkbox"/>	<input type="checkbox"/>
58	monitor buss	Mon 4	<input type="checkbox"/>	<input type="checkbox"/>	<input type="checkbox"/>	<input type="checkbox"/>	<input type="checkbox"/>	<input type="checkbox"/>	<input type="checkbox"/>	<input type="checkbox"/>
59	monitor buss	Mon 5	<input type="checkbox"/>	<input type="checkbox"/>	<input type="checkbox"/>	<input type="checkbox"/>	<input type="checkbox"/>	<input type="checkbox"/>	<input type="checkbox"/>	<input type="checkbox"/>
60	monitor buss	Mon 6	<input type="checkbox"/>	<input type="checkbox"/>	<input type="checkbox"/>	<input type="checkbox"/>	<input type="checkbox"/>	<input type="checkbox"/>	<input type="checkbox"/>	<input type="checkbox"/>
61	monitor buss	Mon 7	<input type="checkbox"/>	<input type="checkbox"/>	<input type="checkbox"/>	<input type="checkbox"/>	<input type="checkbox"/>	<input type="checkbox"/>	<input type="checkbox"/>	<input type="checkbox"/>
62	monitor buss	Mon 8	<input type="checkbox"/>	<input type="checkbox"/>	<input type="checkbox"/>	<input type="checkbox"/>	<input type="checkbox"/>	<input type="checkbox"/>	<input type="checkbox"/>	<input type="checkbox"/>
63	monitor buss	Mon 9	<input type="checkbox"/>	<input type="checkbox"/>	<input type="checkbox"/>	<input type="checkbox"/>	<input type="checkbox"/>	<input type="checkbox"/>	<input type="checkbox"/>	<input type="checkbox"/>
64	monitor buss	Mon 10	<input type="checkbox"/>	<input type="checkbox"/>	<input type="checkbox"/>	<input type="checkbox"/>	<input type="checkbox"/>	<input type="checkbox"/>	<input type="checkbox"/>	<input type="checkbox"/>
65	monitor buss	Mon 11	<input type="checkbox"/>	<input type="checkbox"/>	<input type="checkbox"/>	<input type="checkbox"/>	<input type="checkbox"/>	<input type="checkbox"/>	<input type="checkbox"/>	<input type="checkbox"/>

b. Setup and check Processing preset pools

Axum » Console 1-4 configuration » Preset pools										
Preset pool										
Nr	Label	Console 1		Console 2		Console 3		Console 4		
		A	B	A	B	A	B	A	B	
1	Default	<input type="checkbox"/>	<input checked="" type="checkbox"/>	<input type="checkbox"/>	<input checked="" type="checkbox"/>	<input type="checkbox"/>	<input checked="" type="checkbox"/>	<input type="checkbox"/>	<input checked="" type="checkbox"/>	
2	None	<input type="checkbox"/>	<input checked="" type="checkbox"/>	<input type="checkbox"/>	<input checked="" type="checkbox"/>	<input type="checkbox"/>	<input checked="" type="checkbox"/>	<input type="checkbox"/>	<input checked="" type="checkbox"/>	
3	DJ Prst	<input checked="" type="checkbox"/>	<input checked="" type="checkbox"/>	<input checked="" type="checkbox"/>	<input checked="" type="checkbox"/>	<input checked="" type="checkbox"/>	<input checked="" type="checkbox"/>	<input checked="" type="checkbox"/>	<input checked="" type="checkbox"/>	
4	Ann Prst	<input checked="" type="checkbox"/>	<input checked="" type="checkbox"/>	<input checked="" type="checkbox"/>	<input checked="" type="checkbox"/>	<input checked="" type="checkbox"/>	<input checked="" type="checkbox"/>	<input checked="" type="checkbox"/>	<input checked="" type="checkbox"/>	
5	Gst Prst	<input checked="" type="checkbox"/>	<input checked="" type="checkbox"/>	<input checked="" type="checkbox"/>	<input checked="" type="checkbox"/>	<input checked="" type="checkbox"/>	<input checked="" type="checkbox"/>	<input checked="" type="checkbox"/>	<input checked="" type="checkbox"/>	
6	Hybrid	<input checked="" type="checkbox"/>	<input checked="" type="checkbox"/>	<input checked="" type="checkbox"/>	<input checked="" type="checkbox"/>	<input checked="" type="checkbox"/>	<input checked="" type="checkbox"/>	<input checked="" type="checkbox"/>	<input checked="" type="checkbox"/>	
7	No Proc	<input checked="" type="checkbox"/>	<input checked="" type="checkbox"/>	<input checked="" type="checkbox"/>	<input checked="" type="checkbox"/>	<input checked="" type="checkbox"/>	<input checked="" type="checkbox"/>	<input checked="" type="checkbox"/>	<input checked="" type="checkbox"/>	
8	Eq On	<input checked="" type="checkbox"/>	<input checked="" type="checkbox"/>	<input checked="" type="checkbox"/>	<input checked="" type="checkbox"/>	<input checked="" type="checkbox"/>	<input checked="" type="checkbox"/>	<input checked="" type="checkbox"/>	<input checked="" type="checkbox"/>	
9	Low Cut	<input checked="" type="checkbox"/>	<input checked="" type="checkbox"/>	<input checked="" type="checkbox"/>	<input checked="" type="checkbox"/>	<input checked="" type="checkbox"/>	<input checked="" type="checkbox"/>	<input checked="" type="checkbox"/>	<input checked="" type="checkbox"/>	



c. Setup and check Users setup.

AXUM » Console 1-4 configuration » Users

					Users																										
					Console 1				Console 2				Console 3				Console 4														
					Login Write				Login Write				Login Write				Login Write														
Active account																															
Chipcard account																															
Nr	Active	Username	Password	Logout to idle	User level	Preset				Pool				User level	Preset				Pool				User level	Preset				Pool			
						Nr	Load	Source	Preset	Nr	Load	Source	Preset		Nr	Load	Source	Preset	Nr	Load	Source	Preset		Nr	Load	Source	Preset				
1	y	User1	*****	y	Operator 1	None	n	A	A	Operator 1	None	n	A	A	Operator 1	None	n	A	A	Operator 1	None	n	A	A	Operator 1	None	n	A	A		
2	y	User2	*****	y	Operator 2	None	n	A	A	Operator 2	None	n	A	A	Operator 2	None	n	A	A	Operator 2	None	n	A	A	Operator 2	None	n	A	A		
3	y	Chef1	*****	y	Supervisor 1	None	n	B	B	Supervisor 1	None	n	B	B	Supervisor 1	None	n	All	All	Supervisor 1	None	n	B	B	Supervisor 1	None	n	B	B		
4	y	Chef2	*****	y	Supervisor 2	None	n	B	B	Supervisor 2	None	n	B	B	Supervisor 2	None	n	All	All	Supervisor 2	None	n	B	B	Supervisor 2	None	n	B	B		
5	y	Administrator	*****	y	Administrator	None	n	All	All	Administrator	None	n	All	All	Administrator	None	n	All	All	Administrator	None	n	All	All	Administrator	None	n	All	All		

[Create new user](#)